



EasyClean



High Performance Liquid Filters

- Low cost
- Absolute filtration from 12 to 400 microns
- Manual, Valve and Automatic options
- Flow rate up to 1.3 l/s
- Multiples available for higher flow rates
- 100% clean with every backwash
- Minimal use of fluid for backwash
- Suitable for pressure to 8 bar
- Easy to install
- Easy to maintain
- 5 year guarantee on filter coil

Suitable Applications

- Domestic and light commercial use
- Rain and grey water
- Pre-filtration
- Nozzle protection
- Potable water

The Range

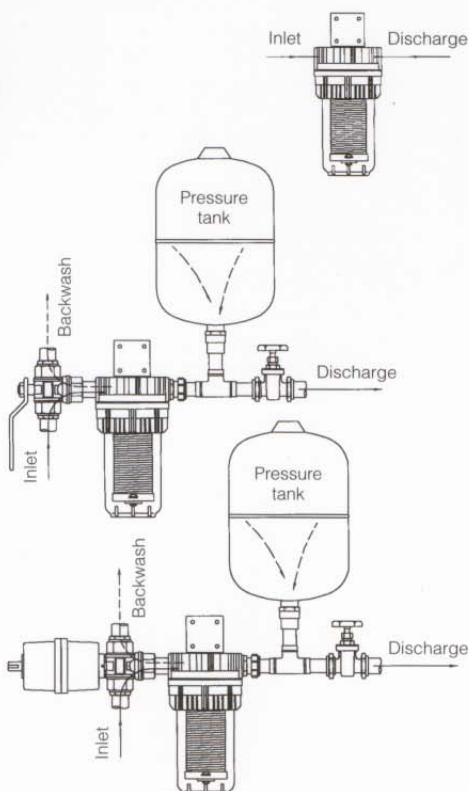

Manual

The EasyClean Manual is a simple, inexpensive yet effective means of low flow rate filtration. Cleaning is achieved by removing the element from its housing and washing it by hand. An excellent solution for applications where pressure for self cleaning is not available.

Valve

The EasyClean Valve offers a way of backwashing quickly and effectively with minimum interruption of flow. A simple 90° turn of the valve handle brings about a thorough backwash in seconds using an insignificant quantity of liquid.

Auto

The EasyClean Auto presents a fully automatic, self cleaning filter comprising controller, pressure vessel, actuator and housed element. The controller can be programmed to meet specific application requirements by altering backwash duration and frequency.

Higher Flow Rates

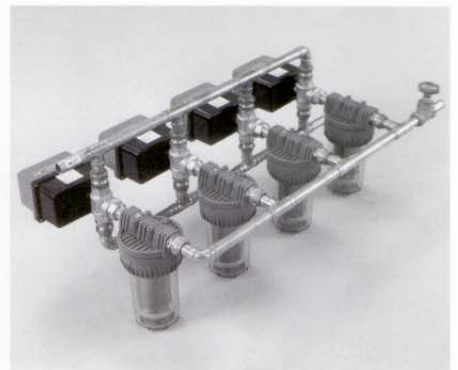

The EasyClean Range can handle higher flow rates by a simple build up of individual units in parallel.

EasyClean Performance

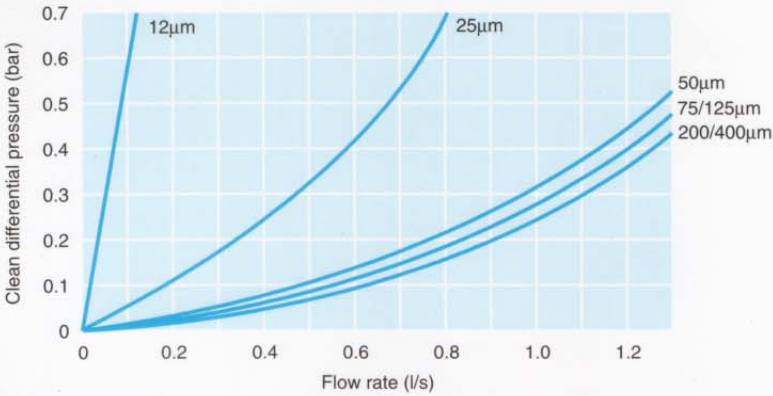

Note: Detailed flow curves available on request.

Specification

Materials

Filter Coil	Stainless steel 304 to aircraft quality DTD 734
Filter Cage	Glass filled polypropylene and stainless steel
Filter Housing	SAN
Adaptor	Virgin polypropylene
Seals	Nitrile rubber
Housing Top	Polypropylene with brass relief valve

Valve and Auto only

Pipework	22mm copper (Table X)
Pressure Tank	8 litre - butyl liner in coated steel
Valve	3/4" BSP three way ball valve

Auto only

Actuator	Nylon and coloured ABS
----------	------------------------

All materials suitable for potable water

Connections Manual

Inlet	3/4" BSP threaded female
Discharge	3/4" BSP threaded female

Valve and Auto only

Inlet	3/4" BSP threaded female
Backwash	3/4" BSP threaded female
Discharge	22mm compression fitting

Dimensions

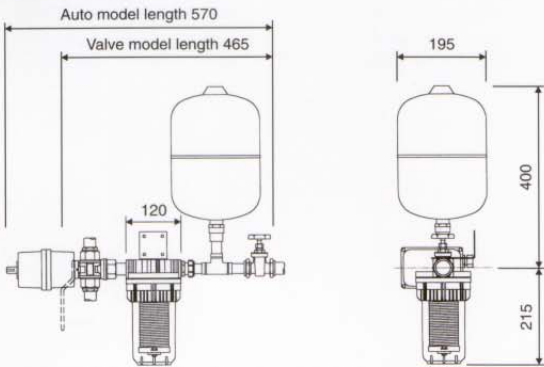

100% Cleaning with Every Backwash

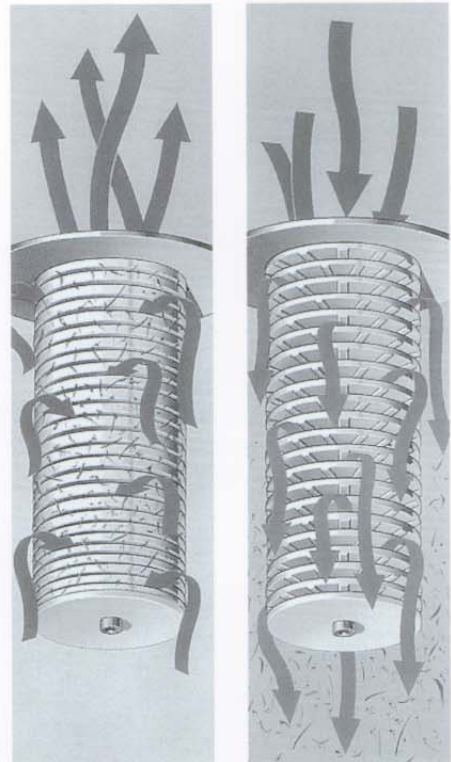

Filtering

Backwashing

The zero gravity coil design enables filter elements to be completely cleaned with every backwash, minimising backwash frequency and water consumption.

Filtration Ratings

Filter elements are available in seven different micron ratings: 12, 25, 50, 75, 125, 200 and 400 and are completely interchangeable. In some heavily contaminated systems, it may be advantageous to install a set of coarse or 'commissioning' elements in the early stages of the filter operation and replace them with finer elements at a later stage once the backwash frequency has stabilised.

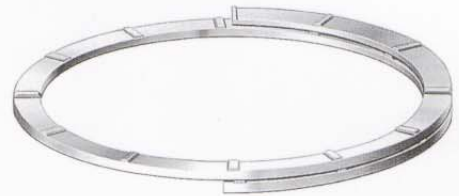

Cross Manufacturing Company (1938) Ltd

Midford Road
Bath BA2 5RR
England

Tel: 01225 837000
Fax: 01225 834115
Email: mail@crossmanufacturing.com
Web Site: www.crossmanufacturing.com

The design of Cross Filters is subject to modification or change without notice.

Distributed by:

