

- Made from High Tensile Spring Steel
- Greater resistance to breakage
- High accuracy rolled section
- Most sizes held in stock

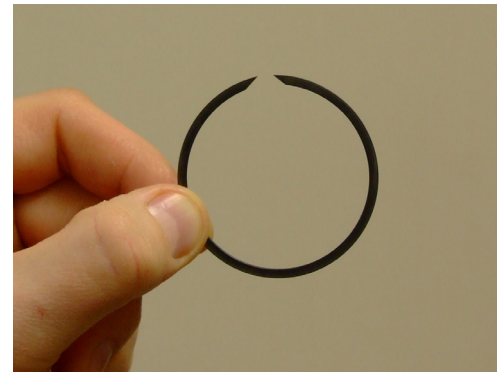

These dimensions relate to the tables on pages 2, 3, 4, 5 & 6. Dimensions in inches unless otherwise stated.

† **NOMINAL SHAFT DIAMETER:**

The shaft onto which the ring is fitted.

\* **SPRING:**

Decrease in gap when ring is released from diameter in position to free position.

**NOTE:** Grain flow is parallel to circumference of ring. For details of grooves see pages 6, 7 & 8.

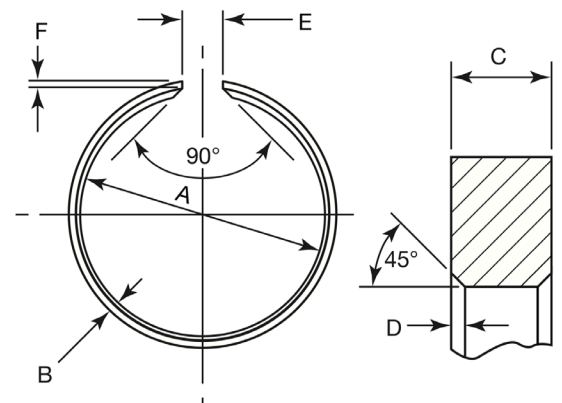

Part No. A.S.	Nominal Shaft Diameter †		A Dia.	B Radial Thickness		C Width Tol: -.002	D Chamfer		E ± .030	F Max.	* Spring		Limit of Speed R.P.M.
	mm	inches		Max.	Tolerance (Minus)		Max.	Min.			Min.	Max.	
4571/1	25		0.950	0.050	0.003	0.060	0.008	0.004	0.200	0.010	0.062	0.085	7,000
4571/2		1.000	0.962	0.056	0.003	0.060	0.008	0.004	0.200	0.010	0.040	0.058	
4571/3	26		0.986	0.056	0.003	0.060	0.008	0.004	0.200	0.010	0.046	0.066	
4571/4		1.050	1.012	0.056	0.003	0.060	0.008	0.004	0.200	0.010	0.054	0.075	6,000
4571/5	27		1.025	0.056	0.003	0.060	0.008	0.004	0.200	0.010	0.060	0.082	
4571/6	28	1.100	1.064	0.056	0.003	0.060	0.008	0.004	0.200	0.010	0.072	0.096	
4571/7		1.125	1.088	0.056	0.003	0.060	0.008	0.004	0.250	0.010	0.080	0.105	
4571/8	29	1.150	1.108	0.056	0.003	0.060	0.008	0.004	0.250	0.010	0.092	0.120	
4571/9	30		1.138	0.064	0.004	0.060	0.008	0.004	0.200	0.010	0.060	0.082	
4571/10		1.200	1.158	0.064	0.004	0.060	0.008	0.004	0.200	0.010	0.068	0.092	
4571/11	31		1.178	0.064	0.004	0.060	0.008	0.004	0.200	0.010	0.075	0.100	
4571/12		1.250	1.212	0.064	0.004	0.060	0.008	0.004	0.250	0.010	0.075	0.100	
4571/12	32		1.212	0.064	0.004	0.060	0.008	0.004	0.250	0.010	0.075	0.100	
4571/13	33	1.300	1.256	0.064	0.004	0.060	0.008	0.004	0.250	0.010	0.092	0.120	
4571/14	34		1.302	0.064	0.004	0.060	0.008	0.004	0.250	0.010	0.100	0.130	
4571/14		1.350	1.302	0.064	0.004	0.060	0.008	0.004	0.250	0.010	0.100	0.130	
4571/15	35	1.375	1.334	0.064	0.004	0.060	0.008	0.004	0.300	0.010	0.120	0.155	
4571/16		1.400	1.354	0.072	0.004	0.060	0.008	0.004	0.250	0.010	0.096	0.125	
4571/17	36		1.370	0.072	0.004	0.060	0.008	0.004	0.250	0.010	0.100	0.130	
4571/18	37	1.450	1.408	0.072	0.004	0.060	0.008	0.004	0.250	0.010	0.110	0.145	
4571/19	38	1.500	1.452	0.072	0.004	0.060	0.008	0.004	0.300	0.010	0.125	0.160	
4571/20	39		1.490	0.072	0.004	0.060	0.008	0.004	0.300	0.010	0.140	0.180	
4571/21		1.550	1.504	0.072	0.004	0.060	0.008	0.004	0.300	0.010	0.145	0.185	
4571/22	40		1.530	0.072	0.004	0.060	0.008	0.004	0.350	0.010	0.155	0.195	
4571/23		1.600	1.546	0.080	0.005	0.060	0.008	0.004	0.300	0.010	0.110	0.145	
4571/24	41		1.566	0.080	0.005	0.060	0.008	0.004	0.300	0.010	0.110	0.145	
4571/24		1.625	1.566	0.080	0.005	0.060	0.008	0.004	0.300	0.010	0.110	0.145	
4571/25	42	1.650	1.598	0.080	0.005	0.060	0.008	0.004	0.300	0.010	0.130	0.165	
4571/26	43	1.700	1.644	0.080	0.005	0.060	0.008	0.004	0.300	0.010	0.140	0.180	
4571/27	44		1.678	0.080	0.005	0.060	0.008	0.004	0.350	0.010	0.160	0.200	
4571/28		1.750	1.696	0.080	0.005	0.060	0.008	0.004	0.350	0.010	0.165	0.210	
4571/29	45		1.718	0.080	0.005	0.060	0.008	0.004	0.350	0.010	0.175	0.220	
4571/30		1.800	1.745	0.090	0.005	0.060	0.008	0.004	0.300	0.010	0.120	0.155	
4571/30	46		1.745	0.090	0.005	0.060	0.008	0.004	0.300	0.010	0.120	0.155	
4571/31	47	1.850	1.790	0.090	0.005	0.060	0.008	0.004	0.350	0.010	0.145	0.185	
4571/32		1.875	1.815	0.090	0.005	0.060	0.008	0.004	0.350	0.010	0.155	0.195	
4571/33	48	1.900	1.835	0.090	0.005	0.060	0.008	0.004	0.350	0.010	0.155	0.195	
4571/34	49		1.870	0.090	0.005	0.060	0.008	0.004	0.350	0.010	0.175	0.220	
4571/35		1.950	1.900	0.090	0.005	0.060	0.008	0.004	0.350	0.010	0.175	0.220	
4571/35	50		1.900	0.090	0.005	0.060	0.008	0.004	0.350	0.010	0.175	0.220	

Part No. A.S.	Nominal Shaft Diameter †		A Dia.	B Radial Thickness		C Width Tol:-.002	D Chamfer		E ± .030	F Max.	* Spring		Limit of Speed R.P.M.
	mm	inches		Max.	Tolerance (Minus)		Max.	Min.			Min.	Max.	
4571/36	51	2.000	1.945	0.090	0.005	0.060	0.008	0.004	0.400	0.010	0.185	0.235	4,000
4571/37	52	2.050	1.990	0.090	0.005	0.060	0.008	0.004	0.400	0.010	0.210	0.265	
4571/38	53		2.035	0.090	0.005	0.060	0.008	0.004	0.450	0.010	0.220	0.275	
4571/38		2.100	2.035	0.090	0.005	0.060	0.008	0.004	0.450	0.010	0.220	0.275	
4571/39	54		2.065	0.090	0.005	0.060	0.008	0.004	0.450	0.010	0.245	0.305	
4571/40		2.150	2.090	0.100	0.005	0.060	0.008	0.004	0.450	0.010	0.180	0.225	
4571/40	55		2.090	0.100	0.005	0.060	0.008	0.004	0.400	0.010	0.180	0.225	
4571/41	56	2.200	2.135	0.100	0.005	0.060	0.008	0.004	0.400	0.010	0.205	0.260	
4571/42	57	2.250	2.180	0.100	0.005	0.060	0.008	0.004	0.450	0.010	0.220	0.275	
4571/43	58		2.225	0.100	0.005	0.060	0.008	0.004	0.450	0.010	0.230	0.285	
4571/43		2.300	2.225	0.100	0.005	0.060	0.008	0.004	0.450	0.010	0.230	0.285	
4571/44	59		2.550	0.100	0.005	0.060	0.008	0.004	0.450	0.010	0.255	0.315	
4571/45		2.350	2.290	0.100	0.005	0.060	0.008	0.004	0.500	0.010	0.260	0.320	
4571/45	60		2.290	0.100	0.005	0.060	0.008	0.004	0.500	0.010	0.260	0.320	
4571/46	61	2.400	2.335	0.100	0.005	0.060	0.008	0.004	0.500	0.010	0.290	0.355	
4571/47	62	2.450	2.370	0.110	0.005	0.080	0.015	0.010	0.450	0.020	0.230	0.285	
4571/48	63		2.405	0.110	0.005	0.080	0.015	0.010	0.450	0.020	0.240	0.300	
4571/49		2.500	2.435	0.110	0.005	0.080	0.015	0.010	0.450	0.020	0.240	0.300	
4571/49	64		2.435	0.110	0.005	0.080	0.015	0.010	0.450	0.020	0.240	0.300	
4571/50	65	2.550	2.480	0.110	0.005	0.080	0.015	0.010	0.500	0.020	0.270	0.335	
4571/51	66	2.600	2.540	0.110	0.005	0.080	0.015	0.010	0.500	0.020	0.280	0.345	
4571/51		2.625	2.540	0.110	0.005	0.080	0.015	0.010	0.500	0.020	0.280	0.345	
4571/52	67		2.575	0.110	0.005	0.080	0.015	0.010	0.550	0.020	0.315	0.390	
4571/52		2.650	2.575	0.110	0.005	0.080	0.015	0.010	0.550	0.020	0.315	0.390	
4571/53	68		2.600	0.110	0.005	0.080	0.015	0.010	0.550	0.020	0.320	0.395	
4571/54		2.700	2.635	0.110	0.005	0.080	0.015	0.010	0.550	0.020	0.320	0.395	
4571/54	69		2.635	0.110	0.005	0.080	0.015	0.010	0.550	0.020	0.320	0.395	
4571/55	70	2.750	2.670	0.120	0.006	0.080	0.015	0.010	0.500	0.020	0.280	0.345	
4571/56	71	2.800	2.720	0.120	0.006	0.080	0.015	0.010	0.550	0.020	0.310	0.380	
4571/57	72		2.760	0.120	0.006	0.080	0.015	0.010	0.550	0.020	0.310	0.380	
4571/57		2.850	2.760	0.120	0.006	0.080	0.015	0.010	0.550	0.020	0.310	0.380	
4571/58	73	2.875	2.790	0.120	0.006	0.080	0.015	0.010	0.550	0.020	0.330	0.405	
4571/59		2.900	2.830	0.120	0.006	0.080	0.015	0.010	0.600	0.020	0.350	0.430	
4571/59	74		2.830	0.120	0.006	0.080	0.015	0.010	0.600	0.020	0.350	0.430	
4571/60	75	2.950	2.870	0.120	0.006	0.080	0.015	0.010	0.600	0.020	0.365	0.450	
4571/61	76	3.000	2.920	0.120	0.006	0.080	0.015	0.010	0.650	0.020	0.390	0.480	
4571/62	77		2.950	0.120	0.006	0.080	0.015	0.010	0.650	0.020	0.390	0.480	
4571/63		3.050	2.980	0.120	0.006	0.080	0.015	0.010	0.650	0.020	0.390	0.480	
4571/63	78		2.980	0.120	0.006	0.080	0.015	0.010	0.650	0.020	0.390	0.480	
4571/64	79	3.100	3.020	0.130	0.006	0.080	0.015	0.010	0.600	0.020	0.350	0.430	
4571/65		3.125	3.050	0.130	0.006	0.080	0.015	0.010	0.600	0.020	0.350	0.430	
4571/65	80	3.150	3.050	0.130	0.006	0.080	0.015	0.010	0.600	0.020	0.350	0.430	
4571/66	81	3.200	3.110	0.130	0.006	0.080	0.015	0.010	0.650	0.020	0.395	0.485	

Part No. A.S.	Nominal Shaft Diameter †		A Dia.	B Radial Thickness		C Width Tol:-.002	D Chamfer		E ± .030	F Max.	* Spring		Limit of Speed R.P.M.
	mm	inches		Max.	Tolerance (Minus)		Max.	Min.			Min.	Max.	
4571/67	82		3.140	0.130	0.006	0.080	0.015	0.010	0.650	0.020	0.400	0.490	3,500
4571/68		3.250	3.170	0.130	0.006	0.080	0.015	0.010	0.650	0.020	0.400	0.490	
4571/68	83		3.170	0.130	0.006	0.080	0.015	0.010	0.650	0.020	0.400	0.490	
4571/69	84	3.300	3.220	0.130	0.006	0.080	0.015	0.010	0.700	0.020	0.440	0.540	
4571/70	85	3.350	3.260	0.130	0.006	0.080	0.015	0.010	0.750	0.020	0.450	0.550	
4571/71	86	3.375	3.290	0.130	0.006	0.080	0.015	0.010	0.750	0.020	0.450	0.550	
4571/72		3.400	3.310	0.130	0.006	0.080	0.015	0.010	0.750	0.020	0.470	0.580	
4571/73	87		3.340	0.130	0.006	0.080	0.015	0.010	0.800	0.020	0.490	0.600	
4571/74		3.450	3.370	0.130	0.006	0.080	0.015	0.010	0.800	0.020	0.490	0.600	
4571/74	88		3.370	0.130	0.006	0.080	0.015	0.010	0.800	0.020	0.490	0.600	
4571/75	89	3.500	3.400	0.145	0.008	0.080	0.015	0.010	0.700	0.020	0.410	0.510	
4571/76	90	3.550	3.450	0.145	0.008	0.080	0.015	0.010	0.700	0.020	0.430	0.530	
4571/77	91		3.490	0.145	0.008	0.080	0.015	0.010	0.750	0.020	0.450	0.550	
4571/77		3.600	3.490	0.145	0.008	0.080	0.015	0.010	0.750	0.020	0.450	0.550	
4571/78	92	3.625	3.530	0.145	0.008	0.080	0.015	0.010	0.750	0.020	0.460	0.560	
4571/79	93	3.650	3.550	0.145	0.008	0.080	0.015	0.010	0.750	0.020	0.470	0.580	
4571/80	94	3.700	3.600	0.145	0.008	0.080	0.015	0.010	0.800	0.020	0.490	0.600	
4571/81	95	3.750	3.650	0.145	0.008	0.080	0.015	0.010	0.800	0.020	0.510	0.620	
4571/82	96		3.680	0.145	0.008	0.080	0.015	0.010	0.850	0.020	0.520	0.640	
4571/83		3.800	3.710	0.145	0.008	0.080	0.015	0.010	0.850	0.020	0.540	0.660	
4571/83	97		3.710	0.145	0.008	0.080	0.015	0.010	0.850	0.020	0.540	0.660	
4571/84	98	3.850	3.760	0.145	0.008	0.080	0.015	0.010	0.900	0.020	0.560	0.680	
4571/85	99	3.900	3.800	0.145	0.008	0.080	0.015	0.010	0.900	0.020	0.580	0.700	
4571/86	100		3.850	0.145	0.008	0.080	0.015	0.010	0.950	0.020	0.600	0.730	
4571/86		3.950	3.850	0.145	0.008	0.080	0.015	0.010	0.950	0.020	0.600	0.730	
4571/87	101		3.880	0.145	0.008	0.080	0.015	0.010	0.950	0.020	0.610	0.740	
4571/88		4.000	3.900	0.160	0.008	0.080	0.015	0.010	0.850	0.020	0.520	0.640	
4571/88	102		3.900	0.160	0.008	0.080	0.015	0.010	0.850	0.020	0.520	0.640	
4571/89	103	4.050	3.940	0.160	0.008	0.080	0.015	0.010	0.850	0.020	0.540	0.660	
4571/90	104	4.100	3.990	0.160	0.008	0.080	0.015	0.010	0.900	0.020	0.560	0.680	
4571/91	105	4.125	4.030	0.160	0.008	0.080	0.015	0.010	0.900	0.020	0.580	0.700	
4571/91		4.150	4.030	0.160	0.008	0.080	0.015	0.010	0.900	0.020	0.580	0.700	
4571/92	106		4.070	0.160	0.008	0.080	0.015	0.010	0.950	0.020	0.590	0.720	
4571/93		4.200	4.100	0.160	0.008	0.080	0.015	0.010	0.950	0.020	0.610	0.740	
4571/93	107		4.100	0.160	0.008	0.080	0.015	0.010	0.950	0.020	0.610	0.740	
4571/94	108	4.250	4.140	0.160	0.008	0.080	0.015	0.010	0.950	0.020	0.630	0.760	
4571/95	109	4.300	4.190	0.160	0.008	0.080	0.015	0.010	1.000	0.020	0.640	0.780	
4571/96	110		4.230	0.160	0.008	0.080	0.015	0.010	1.000	0.020	0.660	0.800	
4571/96		4.350	4.230	0.160	0.008	0.080	0.015	0.010	1.000	0.020	0.660	0.800	
4571/97	111	4.375	4.270	0.160	0.008	0.080	0.015	0.010	1.000	0.020	0.680	0.820	
4571/98	112	4.400	4.300	0.160	0.008	0.080	0.015	0.010	1.000	0.020	0.690	0.840	
4571/99	113	4.450	4.340	0.160	0.008	0.080	0.015	0.010	1.100	0.020	0.720	0.870	
4571/100	114		4.390	0.160	0.008	0.080	0.015	0.010	1.100	0.020	0.730	0.880	

Part No. A.S.	Nominal Shaft Diameter †		A Dia.	B Radial Thickness		C Width Tol: -.002	D Chamfer		E ± .030	F Max.	* Spring		Limit of Speed R.P.M.
	mm	inches		Max.	Tolerance (Minus)		Max.	Min.			Min.	Max.	
4571/100		4.500	4.390	0.160	0.008	0.080	0.015	0.010	1.100	0.020	0.730	0.880	2,500
4571/101	115		4.420	0.160	0.008	0.080	0.015	0.010	1.100	0.020	0.740	0.900	
4571/102		4.550	4.440	0.180	0.010	0.100	0.025	0.020	0.950	0.030	0.610	0.740	
4571/102	116		4.440	0.180	0.010	0.100	0.025	0.020	0.950	0.030	0.610	0.740	
4571/103	117	4.600	4.490	0.180	0.010	0.100	0.025	0.020	0.950	0.030	0.630	0.760	
4571/103		4.625	4.490	0.180	0.010	0.100	0.025	0.020	0.950	0.030	0.630	0.760	
4571/104	118	4.650	4.530	0.180	0.010	0.100	0.025	0.020	1.000	0.030	0.640	0.780	
4571/105	119		4.570	0.180	0.010	0.100	0.025	0.020	1.000	0.030	0.660	0.800	
4571/105		4.700	4.570	0.180	0.010	0.100	0.025	0.020	1.000	0.030	0.660	0.800	
4571/106	120		4.600	0.180	0.010	0.100	0.025	0.020	1.000	0.030	0.670	0.810	
4571/107		4.750	4.640	0.180	0.010	0.100	0.025	0.020	1.000	0.030	0.690	0.830	
4571/107	121		4.640	0.180	0.010	0.100	0.025	0.020	1.000	0.030	0.690	0.830	
4571/108	122	4.800	4.680	0.180	0.010	0.100	0.025	0.020	1.100	0.030	0.700	0.850	
4571/109	123	4.850	4.730	0.180	0.010	0.100	0.025	0.020	1.100	0.030	0.720	0.870	
4571/110	124	4.875	4.770	0.180	0.010	0.100	0.025	0.020	1.100	0.030	0.740	0.900	
4571/110		4.900	4.770	0.180	0.010	0.100	0.025	0.020	1.100	0.030	0.740	0.900	
4571/111	125		4.800	0.180	0.010	0.100	0.025	0.020	1.100	0.030	0.740	0.900	
4571/112	126	4.950	4.840	0.180	0.010	0.100	0.025	0.020	1.200	0.030	0.770	0.940	
4571/113	127	5.000	4.880	0.180	0.010	0.100	0.025	0.020	1.200	0.030	0.790	0.960	
4571/114	128	5.050	4.920	0.180	0.010	0.100	0.025	0.020	1.200	0.030	0.810	0.980	
4571/115	129		4.970	0.180	0.010	0.100	0.025	0.020	1.200	0.030	0.820	1.000	
4571/115		5.100	4.970	0.180	0.010	0.100	0.025	0.020	1.200	0.030	0.820	1.000	
4571/116	130	5.125	5.000	0.180	0.010	0.100	0.025	0.020	1.300	0.030	0.850	1.030	
4571/117	131	5.150	5.030	0.180	0.010	0.100	0.025	0.020	1.300	0.030	0.860	1.040	
4571/118	132	5.200	5.080	0.180	0.010	0.100	0.025	0.020	1.300	0.030	0.870	1.050	
4571/119	133		5.110	0.200	0.010	0.100	0.025	0.020	1.100	0.030	0.740	0.900	
4571/119		5.250	5.110	0.200	0.010	0.100	0.025	0.020	1.100	0.030	0.740	0.900	
4571/120	134		5.140	0.200	0.010	0.100	0.025	0.020	1.100	0.030	0.740	0.900	
4571/121		5.300	5.180	0.200	0.010	0.100	0.025	0.020	1.200	0.030	0.760	0.930	
4571/121	135		5.180	0.200	0.010	0.100	0.025	0.020	1.200	0.030	0.760	0.930	
4571/122	136	5.350	5.220	0.200	0.010	0.100	0.025	0.020	1.200	0.030	0.790	0.960	
4571/123		5.375	5.250	0.200	0.010	0.100	0.025	0.020	1.200	0.030	0.810	0.980	
4571/123	137	5.400	5.250	0.200	0.010	0.100	0.025	0.020	1.200	0.030	0.810	0.980	
4571/124	138		5.310	0.200	0.010	0.100	0.025	0.020	1.300	0.030	0.830	1.010	
4571/25	139		5.340	0.200	0.010	0.100	0.025	0.020	1.300	0.030	0.840	1.020	
4571/26	140	5.500	5.370	0.200	0.010	0.100	0.025	0.020	1.300	0.030	0.860	1.040	
4571/27	141	5.550	5.420	0.200	0.010	0.100	0.025	0.020	1.300	0.030	0.870	1.050	
4571/28	142	5.600	5.460	0.200	0.010	0.100	0.025	0.020	1.300	0.030	0.900	1.080	
4571/29	143	5.625	5.510	0.200	0.010	0.100	0.025	0.020	1.400	0.030	0.920	1.110	
4571/29		5.650	5.510	0.200	0.010	0.100	0.025	0.020	1.400	0.030	0.920	1.110	
4571/30	144		5.400	0.200	0.010	0.100	0.025	0.020	1.400	0.030	0.930	1.120	
4571/31	145	5.700	5.570	0.200	0.010	0.100	0.025	0.020	1.400	0.030	0.940	1.140	
4571/32	146	5.750	5.620	0.200	0.010	0.100	0.025	0.020	1.400	0.030	0.960	1.160	

Part No. A.S.	Nominal Shaft Diameter †		A Dia.	B Radial Thickness		C Width Tol: -.002	D Chamfer		E ± .030	F Max.	* Spring		Limit of Speed R.P.M.
	mm	inches		Max.	Tolerance (Minus)		Max.	Min.			Min.	Max.	
4571/33	147		5.660	0.200	0.010	0.100	0.025	0.020	1.400	0.030	0.980	1.190	2,000
4571/33		5.800	5.660	0.200	0.010	0.100	0.025	0.020	1.400	0.030	0.980	1.190	
4571/34	148		5.690	0.200	0.010	0.100	0.025	0.020	1.500	0.030	0.990	1.200	
4571/35		5.850	5.730	0.200	0.010	0.100	0.025	0.020	1.500	0.030	1.010	1.220	
4571/35	149	5.875	5.730	0.200	0.010	0.100	0.025	0.020	1.500	0.030	1.010	1.220	
4571/36	150	5.900	5.770	0.200	0.010	0.100	0.025	0.020	1.500	0.030	1.010	1.220	
4571/37	151	5.950	5.810	0.200	0.010	0.100	0.025	0.020	1.500	0.030	1.020	1.230	1,800
4571/38	152		5.860	0.200	0.010	0.100	0.025	0.020	1.500	0.030	1.030	1.250	
4571/38		6.000	5.860	0.200	0.010	0.100	0.025	0.020	1.500	0.030	1.030	1.250	

# CIRCLIPS

## Groove Sizes

Dimensions in inches unless otherwise stated.

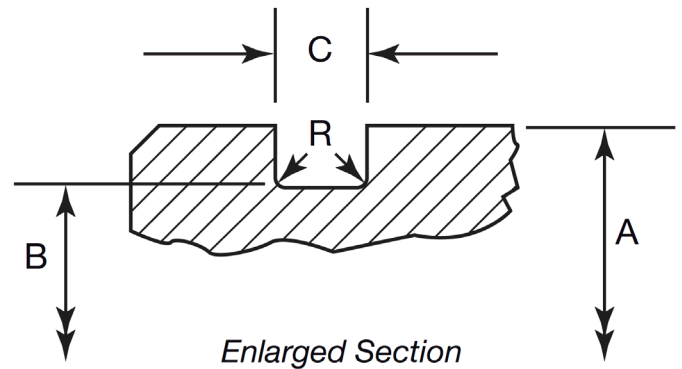

Shaft Dia. A		B Dia.	Tolerance (Minus)	C Width	R Radius	
mm	inches				Max.	Min.
25		0.950	0.003	0.080	0.004	Zero
	1.000	0.962	0.003	0.080	0.004	Zero
26		0.986	0.003	0.080	0.004	Zero
	1.050	1.012	0.0036	0.080	0.004	Zero
27		1.025	0.0036	0.080	0.004	Zero
28	1.100	1.064	0.0036	0.080	0.004	Zero
	1.125	1.088	0.0036	0.080	0.004	Zero
29	1.150	1.108	0.0036	0.080	0.004	Zero
30		1.140	0.0036	0.080	0.004	Zero
	1.200	1.155	0.0036	0.080	0.004	Zero
31		1.175	0.0036	0.080	0.004	Zero
	1.250	1.208	0.0036	0.080	0.004	Zero
32		1.218	0.0036	0.080	0.004	Zero
33	1.300	1.255	0.0036	0.080	0.004	Zero
34		1.296	0.0036	0.080	0.004	Zero
	1.350	1.306	0.0036	0.080	0.004	Zero
35	1.375	1.335	0.0036	0.080	0.004	Zero
	1.400	1.354	0.0036	0.080	0.004	Zero
36		1.370	0.0036	0.080	0.004	Zero
37	1.450	1.408	0.0036	0.080	0.004	Zero
38	1.500	1.452	0.0036	0.080	0.004	Zero
39		1.490	0.0036	0.080	0.004	Zero
	1.550	1.504	0.0042	0.080	0.004	Zero
40		1.530	0.0042	0.080	0.004	Zero

Shaft Dia. A		B Dia.	Tolerance (Minus)	C Width	R Radius	
mm	inches				Max.	Min.
	1.600	1.546	0.0042	0.080	0.004	Zero
41		1.560	0.0042	0.080	0.004	Zero
	1.625	1.572	0.0042	0.080	0.004	Zero
42	1.650	1.598	0.0042	0.080	0.004	Zero
43	1.700	1.644	0.0042	0.080	0.004	Zero
44		1.678	0.0042	0.080	0.004	Zero
	1.750	1.696	0.0042	0.080	0.004	Zero
45		1.718	0.0042	0.080	0.004	Zero
	1.800	1.740	0.0042	0.080	0.004	Zero
46		1.750	0.0042	0.080	0.004	Zero
47	1.850	1.790	0.0042	0.080	0.004	Zero
	1.875	1.815	0.0042	0.080	0.004	Zero
48	1.900	1.835	0.0042	0.080	0.004	Zero
49		1.870	0.0042	0.080	0.004	Zero
	1.950	1.890	0.0042	0.080	0.004	Zero
50		1.910	0.0042	0.080	0.004	Zero
51	2.000	1.945	0.0042	0.080	0.004	Zero
52	2.050	1.990	0.0042	0.080	0.004	Zero
53		2.030	0.0042	0.080	0.004	Zero

Shaft Dia. A		B Dia.	Tolerance (Minus)	C Width	R Radius	
mm	inches				Max.	Min.
	2.100	2.040	0.0042	0.080	0.004	Zero
54		2.065	0.0042	0.080	0.004	Zero
	2.150	2.085	0.0042	0.080	0.004	Zero
55		2.100	0.0048	0.080	0.004	Zero
56	2.200	2.135	0.0048	0.080	0.004	Zero
57	2.250	2.180	0.0048	0.080	0.004	Zero
58		2.215	0.0048	0.080	0.004	Zero
	2.300	2.235	0.0048	0.080	0.004	Zero
59		2.255	0.0048	0.080	0.004	Zero
	2.350	2.285	0.0048	0.080	0.004	Zero
60		2.295	0.0048	0.080	0.004	Zero
61	2.400	2.335	0.0048	0.080	0.004	Zero
62	2.450	2.370	0.0048	0.100	0.010	0.005
63		2.405	0.0048	0.100	0.010	0.005
	2.500	2.425	0.0048	0.100	0.010	0.005
64		2.445	0.0048	0.100	0.010	0.005
65	2.550	2.480	0.0048	0.100	0.010	0.005
66	2.600	2.530	0.0048	0.100	0.010	0.005
	2.625	2.550	0.0048	0.100	0.010	0.005
67		2.570	0.0048	0.100	0.010	0.005
	2.650	2.580	0.0048	0.100	0.010	0.005
68		2.600	0.0048	0.100	0.010	0.005
	2.700	2.630	0.0048	0.100	0.010	0.005
69		2.640	0.0048	0.100	0.010	0.005
70	2.750	2.678	0.0048	0.100	0.010	0.005
71	2.800	2.720	0.0048	0.100	0.010	0.005
72		2.750	0.0048	0.100	0.010	0.005
	2.850	2.770	0.0048	0.100	0.010	0.005
73	2.875	2.790	0.0048	0.100	0.010	0.005
	2.900	2.820	0.0054	0.100	0.010	0.005
74		2.830	0.0054	0.100	0.010	0.005
75	2.950	2.870	0.0054	0.100	0.010	0.005
76	3.000	2.920	0.0054	0.100	0.010	0.005
77		2.950	0.0054	0.100	0.010	0.005
	3.050	2.970	0.0054	0.100	0.010	0.005
78		2.990	0.0054	0.100	0.010	0.005
79	3.100	3.020	0.0054	0.100	0.010	0.005
	3.125	3.040	0.0054	0.100	0.010	0.005
80	3.015	3.060	0.0054	0.100	0.010	0.005
81	3.200	3.110	0.0054	0.100	0.010	0.005
82		3.140	0.0054	0.100	0.010	0.005
	3.250	3.160	0.0054	0.100	0.010	0.005
83		3.180	0.0054	0.100	0.010	0.005
84	3.300	3.220	0.0054	0.100	0.010	0.005
85	3.350	3.260	0.0054	0.100	0.010	0.005
86	3.375	3.290	0.0054	0.100	0.010	0.005

Shaft Dia. A		B Dia.	Tolerance (Minus)	C Width	R Radius	
mm	inches				Max.	Min.
	3.400	3.310	0.0054	0.100	0.010	0.005
87		3.340	0.0054	0.100	0.010	0.005
	3.450	3.360	0.0054	0.100	0.010	0.005
88		3.380	0.0054	0.100	0.010	0.005
89	3.500	3.400	0.0054	0.100	0.010	0.005
90	3.550	3.450	0.0054	0.100	0.010	0.005
91		3.480	0.0054	0.100	0.010	0.005
	3.600	3.500	0.0054	0.100	0.010	0.005
92	3.625	3.530	0.0054	0.100	0.010	0.005
93	3.650	3.550	0.0054	0.100	0.010	0.005
94	3.700	3.600	0.0054	0.100	0.010	0.005
95	3.750	3.650	0.0054	0.100	0.010	0.005
96		3.680	0.0054	0.100	0.010	0.005
	3.800	3.700	0.0054	0.100	0.010	0.005
97		3.720	0.0054	0.100	0.010	0.005
98	3.850	3.760	0.0054	0.100	0.010	0.005
99	3.900	3.800	0.0054	0.100	0.010	0.005
100		3.840	0.0054	0.100	0.010	0.005
	3.950	3.850	0.0054	0.100	0.010	0.005
101		3.880	0.0054	0.100	0.010	0.005
	4.000	3.890	0.006	0.100	0.010	0.005
102		3.910	0.006	0.100	0.010	0.005
103	4.050	3.940	0.006	0.100	0.010	0.005
104	4.100	3.990	0.006	0.100	0.010	0.005
105	4.125	4.020	0.006	0.100	0.010	0.005
	4.150	4.040	0.006	0.100	0.010	0.005
106		4.070	0.006	0.100	0.010	0.005
	4.200	4.090	0.006	0.100	0.010	0.005
107		4.110	0.006	0.100	0.010	0.005
108	4.250	4.140	0.006	0.100	0.010	0.005
109	4.300	4.190	0.006	0.100	0.010	0.005
110		4.220	0.006	0.100	0.010	0.005
	4.350	4.240	0.006	0.100	0.010	0.005
111	4.375	4.270	0.006	0.100	0.010	0.005
112	4.400	4.300	0.006	0.100	0.010	0.005
113	4.450	4.340	0.006	0.100	0.010	0.005
114		4.380	0.006	0.100	0.010	0.005
	4.500	4.390	0.006	0.100	0.010	0.005
115		4.420	0.006	0.100	0.010	0.005
	4.550	4.430	0.006	0.120	0.020	0.015
116		4.450	0.006	0.120	0.020	0.015
117	4.600	4.480	0.006	0.120	0.020	0.015
	4.625	4.500	0.006	0.120	0.020	0.015
118	4.650	4.530	0.006	0.120	0.020	0.015
119		4.560	0.006	0.120	0.020	0.015
	4.700	4.580	0.006	0.120	0.020	0.015

Shaft Dia. A		B Dia.	Tolerance (Minus)	C Width	R Radius	
mm	inches				Max.	Min.
120		4.600	0.006	0.120	0.020	0.015
	4.750	4.630	0.006	0.120	0.020	0.015
121		4.650	0.006	0.120	0.020	0.015
122	4.800	4.680	0.006	0.120	0.020	0.015
123	4.850	4.730	0.006	0.120	0.020	0.015
124	4.875	4.760	0.006	0.120	0.020	0.015
	4.900	4.780	0.006	0.120	0.020	0.015
125		4.800	0.006	0.120	0.020	0.015
126	4.950	4.840	0.006	0.120	0.020	0.015
127	5.000	4.880	0.006	0.120	0.020	0.015
128	5.050	4.920	0.006	0.120	0.020	0.015
129		4.960	0.006	0.120	0.020	0.015
	5.100	4.980	0.006	0.120	0.020	0.015
130	5.125	5.000	0.006	0.120	0.020	0.015
131	5.150	5.030	0.006	0.120	0.020	0.015
132	5.200	5.080	0.006	0.120	0.020	0.015
133		5.100	0.008	0.120	0.020	0.015
	5.250	5.120	0.008	0.120	0.020	0.015
134		5.140	0.008	0.120	0.020	0.015
	5.300	5.170	0.008	0.120	0.020	0.015
135		5.180	0.008	0.120	0.020	0.015
136	5.350	5.220	0.008	0.120	0.020	0.015

Shaft Dia. A		B Dia.	Tolerance (Minus)	C Width	R Radius	
mm	inches				Max.	Min.
	5.375	5.240	0.008	0.120	0.020	0.015
137	5.400	5.260	0.008	0.120	0.020	0.015
138		5.300	0.008	0.120	0.020	0.015
	5.450	5.320	0.008	0.120	0.020	0.015
139		5.340	0.008	0.120	0.020	0.015
140	5.500	5.370	0.008	0.120	0.020	0.015
141	5.550	5.420	0.008	0.120	0.020	0.015
142	5.600	5.460	0.008	0.120	0.020	0.015
143	5.625	5.500	0.008	0.120	0.020	0.015
	5.650	5.520	0.008	0.120	0.020	0.015
144		5.540	0.008	0.120	0.020	0.015
145	5.700	5.570	0.008	0.120	0.020	0.015
146	5.750	5.620	0.008	0.120	0.020	0.015
147		5.650	0.008	0.120	0.020	0.015
	5.800	5.670	0.008	0.120	0.020	0.015
148		5.690	0.008	0.120	0.020	0.015
	5.850	5.720	0.008	0.120	0.020	0.015
149	5.875	5.740	0.008	0.120	0.020	0.015
150	5.900	5.770	0.008	0.120	0.020	0.015
151	5.950	5.810	0.008	0.120	0.020	0.015
152		5.850	0.008	0.120	0.020	0.015
	6.000	5.870	0.008	0.120	0.020	0.015

AS9100, Rev D  
ISO9001: 2015  
ISO14001: 2015



**Cross Manufacturing Company (1938) Ltd.**

Head Office,  
Midford Road,  
Bath,  
BA2 5RR,  
England

**Tel:** +44 (0) 1225 837000

**Fax:** +44 (0) 1225 834115

mail@crossmanufacturing.com  
www.crossmanufacturing.com